

1. RP001/RP01A/RP003/PC03 輔助拖輪
 Puller Mechanism For RP001/RP01A/RP01B/RP003/PC03

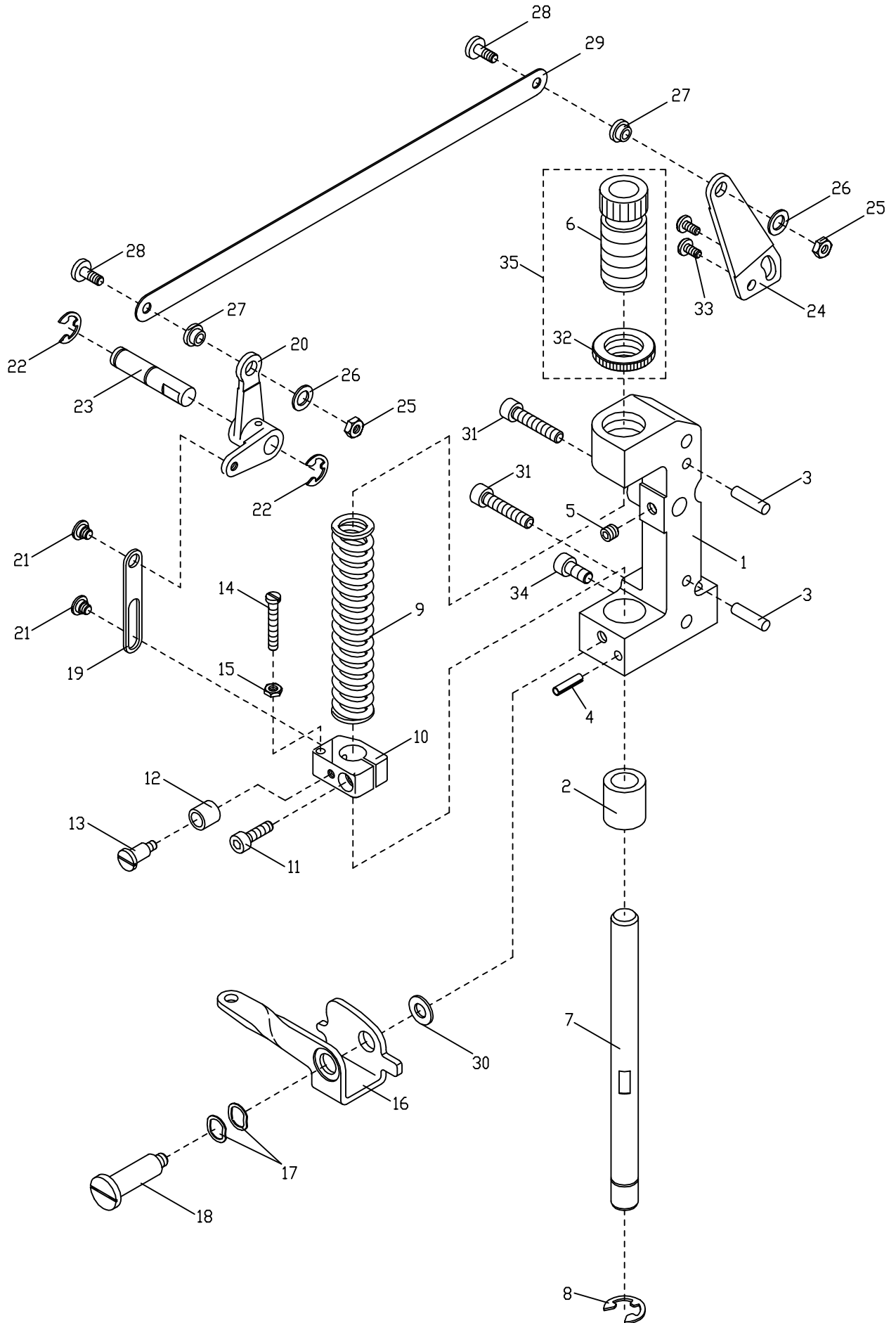

1. RP001/RP01A/RP003/PC03 輔助拖輪

Puller Mechanism For RP001/RP01A/RP003/PC03

序號 Ref. No.	物料編號 Parts No.	名稱 Description	單位用量 Amt. Req.
1	4RP0010101	機架 Upper Feed Roller Bracket -----	1
2	4RP0010102	軸襯 Roller Press Bar Bushing -----	1
3	4RP0010103	定位梢 Knock Pin -----	2
4	90SP0416	止動梢 Stop Pin -----	1
5	8MN06400500A	螺絲 Screw (CT0513 M6-1*5) -----	1
6	2310001221	調壓螺椿 Spring Regulator -----	1
7	4RP0010107	軸 Upper Feed Rrller Press Bar -----	1
8	90ER100	扣環 Retaining Ring -----	1
9	4RP0010109	壓力彈簧 Roller Press Spring -----	1
10	4RP0010110	彈簧座 Roller Press Bar Bracket -----	1
11	8MM05321609A	螺絲 Screw (RP0111 M5-0.8*16) -----	1
12	4RP0010112	套管 Lifting Lever Sleeve -----	1
13	8SB44401510G	螺椿 Stud (RP0113 11/64"-40*14.6) -----	1
14	8SB44403006A	螺絲 Screw (RP0114 11/64"*30) -----	1
15	8SA44400307A	螺帽 Nut (SH0914 11/64"-40*2.5) -----	1
16	4RP0010116	揚昇手柄 Upper Feed Roller Lifting Lever -----	1
17	90WW105	波形墊圈 Corrugated Washer -----	2
18	8MB06403516G	螺椿 Stud (RP0118 M6-1*35) -----	1
19	4RP0010119	吊桿 Lifter Connecting Plate -----	1
20	4RP0010120	吊臂 Right Upper Feed Roller Arm -----	1
21	8SB48320510G	螺絲 Screw (RP0121 3/16"-32*5) -----	2
22	90ER080	扣環 Retaining Ring -----	2
23	4RP0010123	軸 Upper Feed Roller Lifter Pin -----	1
24	4RP0010124	吊臂 Left Upper Feed Roller Arm -----	1
25	8SA44400307A	螺帽 Nut (SH0914 11/64"*2.5)-----	2
26	2100000526	墊圈 Washer -----	2
27	4RP0010127	隔環 Spacer -----	2
28	8SB44401110B	螺絲 Screw (RP0128 11/64"-40*11) -----	2
29	4RP0010129	拉桿 Lifter Connecting Plate -----	1
30	2100000645	墊圈 Washer -----	1
31	8MM06403010A	螺絲 Screw (NT67-01-17 M6-1*30) -----	2
32	2310001222	螺帽 Nut -----	1
33	8MP05320810A	螺絲 Screw (STB0117 M5-0.8*8) -----	2
34	8MM06401210A	螺絲 Screw (FT1103 M6-1*12) -----	1
35	231A0001244	調壓螺椿組 Spring Regulator Asm.-----	1

2. RP001 輔助拖輪 Puller Mechanism For RP001

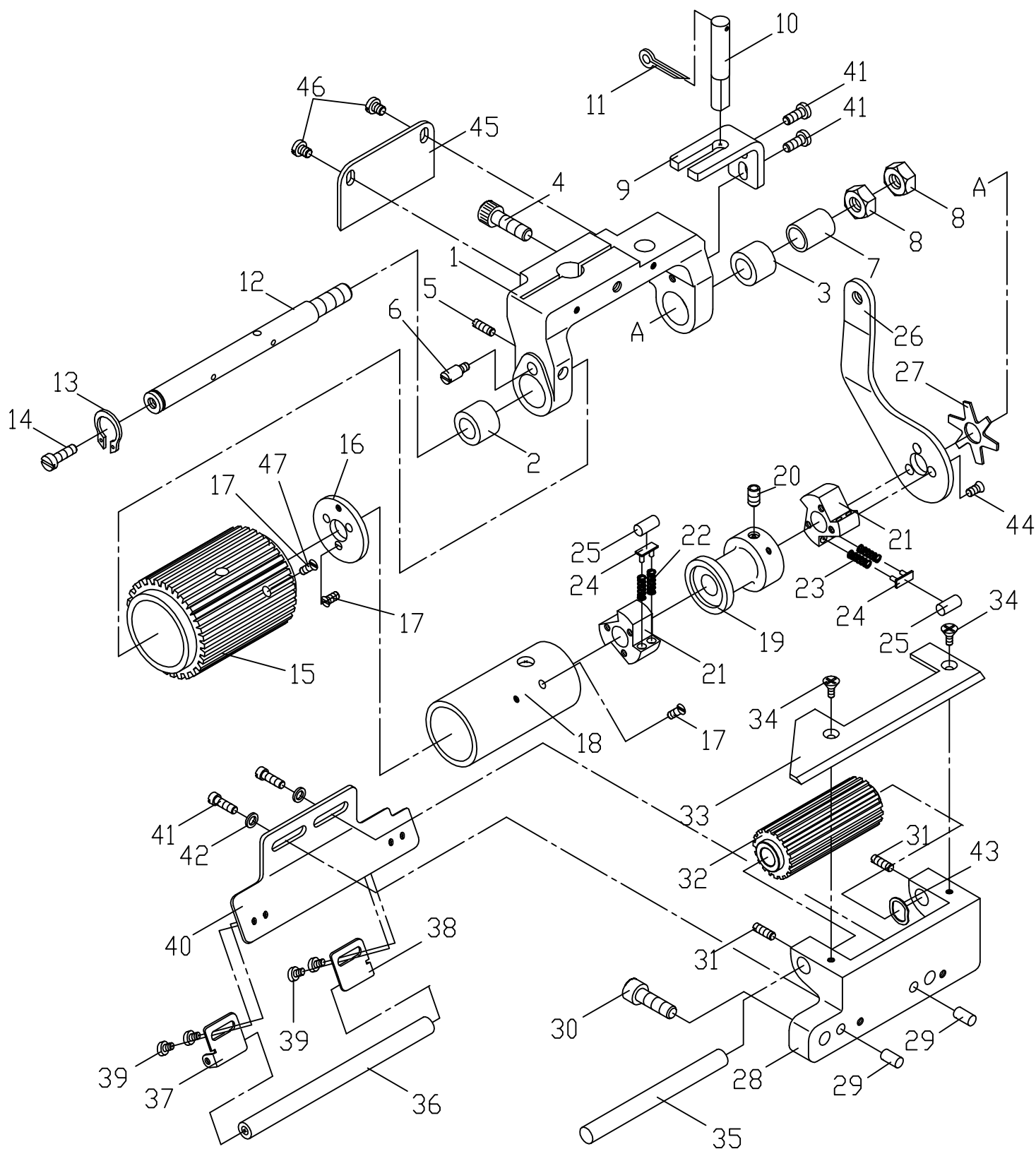

序號	A組 A-TYPE	B組 B-TYPE	C組 C-TYPE	D組 D-TYPE	E組 E-TYPE
15	4RP0010215-30 (RP10215-30)	4RP0010215-26 (RP10215-26)	4RP0010215-24 (RP10215-24)	4RP0010215-20 (RP10215-20)	4RP0010215-0 (RP10215-0)
17	8SF36400606A * 9pcs				8SF36400606A *6pcs
47					8SB36400606K *3pcs

序號	A組 A-TYPE	B組 B-TYPE	C組 C-TYPE	D組 D-TYPE	E組 E-TYPE
32	4RP0010232-15 (RP10232-15)	4RP0010232-13 (RP10232-13)	4RP0010232-12 (RP10232-12)	4RP0010232-10 (RP10232-10)	4RP0010232-0 (RP10232-0)

2. RP001 輔助拖輪 Puller Mechanism For RP001

序號 Ref. No.	物料編號 Parts No.	名稱 Description	單位用量 Amt. Req.
1	4RP0010201	主動輪座 Upper Feed Roller Yoke -----	1
2	4RP0010202	軸襯 Left Clutch Driving Shaft Bushing -----	1
3	4RP0010203	軸襯 Right Clutch Driving Shaft Bushing -----	1
4	8MM06402010A	螺絲 Screw(SH0444 M6-1*20) -----	1
5	8MN04280400A	螺絲 Screw(CT0229 M4-0.7*4) -----	2
6	4RP0010206	止動梢 Stop Pin -----	1
7	4RP0010207	襯套 Clutch Tension Sleeve -----	1
8	8MA08500613A	螺帽 Nut(RP0208 M8-1.25*6) -----	2
9	4RP0010209	導軌 Yoke Guide -----	1
10	4RP0010210	軸 Yoke Pin -----	1
11	-----	-----	-
12	4RP0010212	主動輪軸 Clutch Driving Shaft -----	1
13	90ER090	扣環 Retaining Ring -----	1
14	8MB05320710A	螺絲 Screw(M5-0.8*7) -----	1
15	-----	主動輪 Upper Feed Roller (See Left Page) -----	1
16	4RP0010216	封蓋 Clutch Cheek Plate -----	1
17	8SF36400606A	螺絲 Sctew(RP0217 9/64"-40*6) -----	-
18	4RP0010218	套'筒 Clutch Sleeve -----	1
19	4RP0010219	隔環 Clutch Spacer -----	1
20	8MM06400600A	螺絲 Screw(CT0244 M6-1*6) -----	1
21	4RP00102211	離合器 Clutch -----	2
22	4RPC030222	彈簧 Clutch Spring -----	12
23	-----	-----	-
24	4RP0010224	滾珠座 Clutch Roller Base -----	6
25	4RP0010225	滾珠 Clutch Roller -----	6
26	4RP0010226	拉柄 Clutch Driving Lever -----	1
27	4RP0010227	星形壓環 Clutch Tension Spring -----	1
28	4RP0010228	從動輪座 Lower Feed Roller Support -----	1
29	4RP0010103	定位梢 Knock Pin -----	2
30	8MM06401210A	螺絲 Screw(FT1103 M6-1*12) -----	2
31	8MN04280400A	螺絲 Sctew(CT0229 M4-0.7*4) -----	2
32	-----	從動輪 Lower Feed Roller (See Left Page) -----	1
33	4RP0010233	蓋板 Lower Feed Roller Cover -----	1
34	8ME03200606A	螺絲 Screw(CT0235 M3-0.5*6) -----	2
35	4RP0010235	從動輪軸 Lower feed Roller Shaft -----	1
36	4RP0010236	輔助滾柱 Supplementary Roller -----	1
37	4RP0010237	滾柱架(左) Left Supplementary Roller Stay -----	1
38	4RP0010238	滾柱架(右) Ringt Supplementary Roller Stay -----	1
39	8SC32440406B	螺絲 Screw(PF0128 1/8"-44*4) -----	4
40	4RP0010240	滾柱座 Supplementary Roller Support -----	1
41	8MB04280807K	螺絲 Screw(CT0215 M4-0.7*8) -----	4
42	2100000223	墊圈 Washer -----	2
43	4RP0010243	波形墊圈 Corrugated Washer -----	1
44	8SF36400506A	螺絲 Screw(RP01A02-17 9/64"-40*4.6) -----	3
45	4RP0010245	蓋板 Lower Feed Roller Cover -----	1
46	8MB04280507K	螺絲 Screw (FT0235 M4-0.7*5) -----	2
47	8SB36400606K	螺絲 Screw (RP10244 9/64"-40*5.8) -----	-

3. RP001 / RP01A / RP003 / RPC03 / RP004 / RPC04 / RP008 / RPC08
 RPC09 輔助拖輪 Puller Mechanism

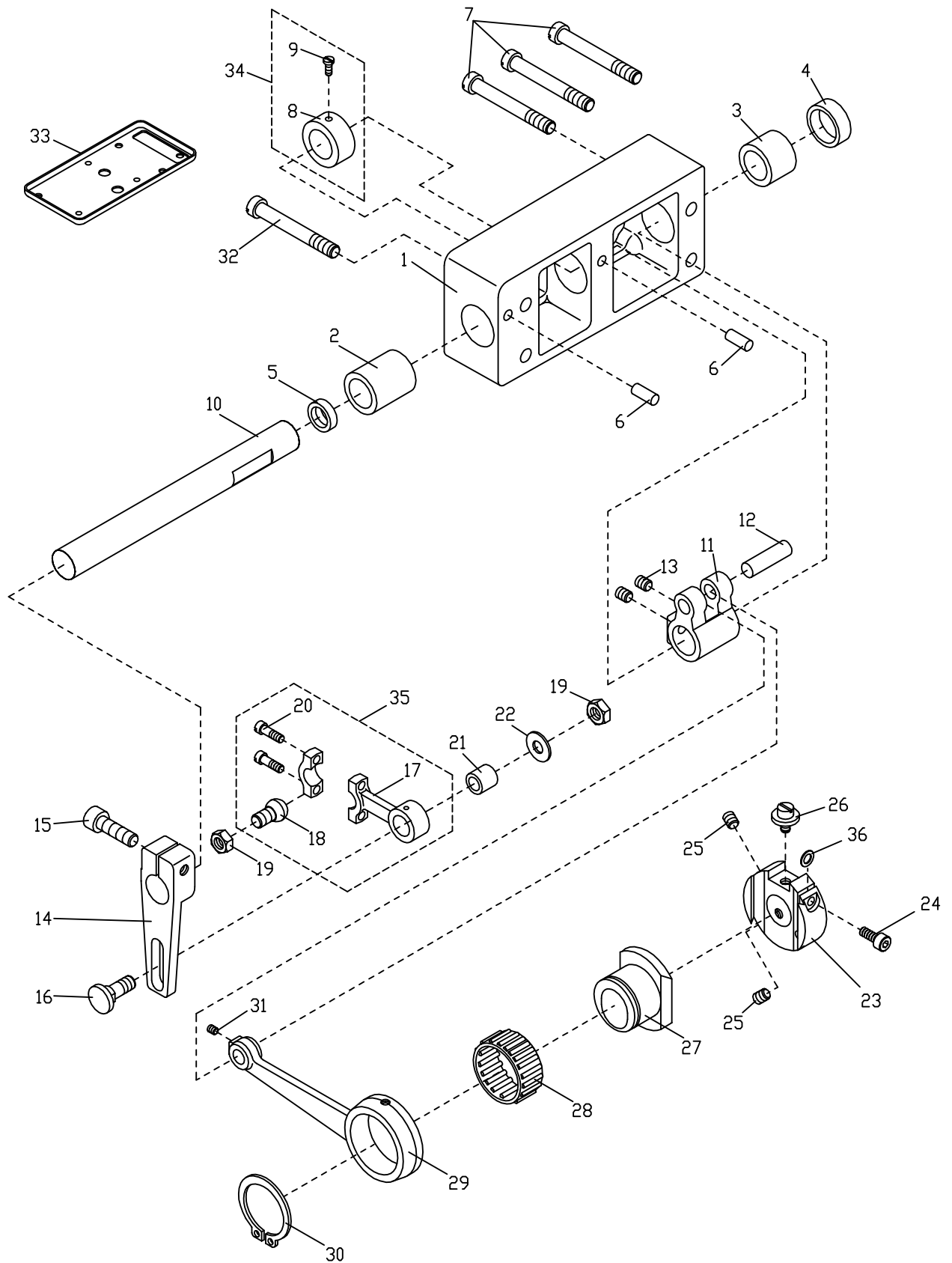

3. RP001 / RP01A / RP003 / RPC03 / RP004 / RPC04 / RP008 / RPC08 / RPC09

輔助拖輪 Puller Mechanism

序號 Ref. No.	物料編號 Parts No.	名稱 Description	單位用量 Amt. Req.
1	4RP0010301	軸承座 Upper Feed Roller Shaft Bracket -----	1
2	4RP0010302	軸襯 Left Roller Shaft Bushing -----	1
3	4RP0010303	軸襯 Right Roller Shaft Bushing -----	1
4	22000002451	孔塞 Seal Plug (白色)-----	1
5	4RP0010305	油封 Oil Seal -----	1
6	4RP0010103	定位梢 Knock Pin -----	2
7	8MM06403510B	螺絲 Screw(RP0307 M6-1*35) -----	3
8	4RP0010308	定位環 Collar -----	1
9	8SN44400400E	螺絲 Screw(SH0104 11/64"-40*4) -----	2
10	4RP0010310	軸 Upper Feed Roller Shaft -----	1
11	4RP0010311	曲柄 Upper Feed Roller Shaft Lever -----	1
12	4RP0010312	曲柄梢 Upper Feed Roller Driving Rod Pin -----	1
13	8MN06400600A	螺絲 Screw(CT0244 M6-1*6) -----	2
14	4RP0010314	拉臂 Upper Feed Roller Arm -----	1
15	8MM06402010A	螺絲 Screw(SH0444 M6-1*20) -----	1
16	4RP0010316	連桿梢 Uper Feed Roller Lever Pin -----	1
17	4RP0010317	連桿 Upper Feed Roller Lever Rod -----	1
18	4RP0010318	球狀接頭 Ball Stud -----	1
19	8SA64400409B	螺帽 Nut(RP0319 1/4"-40*4) -----	2
20	8SB36401106B	螺絲 Screw(RP0320 9/64"-40*11) -----	2
21	4RP0010321	襯套 Upper Feed Roller Lever Rod Bushing-----	1
22	2210001007	墊圈 Washer (FT1007)-----	1
23	4RP0010323	滑軌 Upper Feed Roller Regulator -----	1
24	8MM04281007A	螺絲 Screw(F02-03 M4-0.7*10) -----	1
25	8MN05320500E	螺絲 Screw(CT0903 M5-0.8*5) -----	2
26	4RP0010326	調整螺椿 Adjusting Stud -----	1
27	4RP0010327	滑塊 Upper Feed Roller Eccentric -----	1
28	90NB252913	滾針軸承 Roller Bearing -----	1
29	4RP0010329	連桿 Upper Feed Roller Driving Rod -----	1
30	2200001106	扣環 Retaining Ring -----	1
31	8MN04280400A	螺絲 Screw(C02-29 M4-0.7*4) -----	1
32	8MM06403210B	螺絲 Screw(RP0307 M6-1*35) -----	1
33	4RP0010333	承油盤 Oil Receiver -----	1
34	4RP001A0334	定位環組 Collar Asm -----	1
35	4RP001A0335	連桿組 Upper Feed Roller Lever Rod Asm -----	1
36	2100000640	墊圈 Washer -----	1